

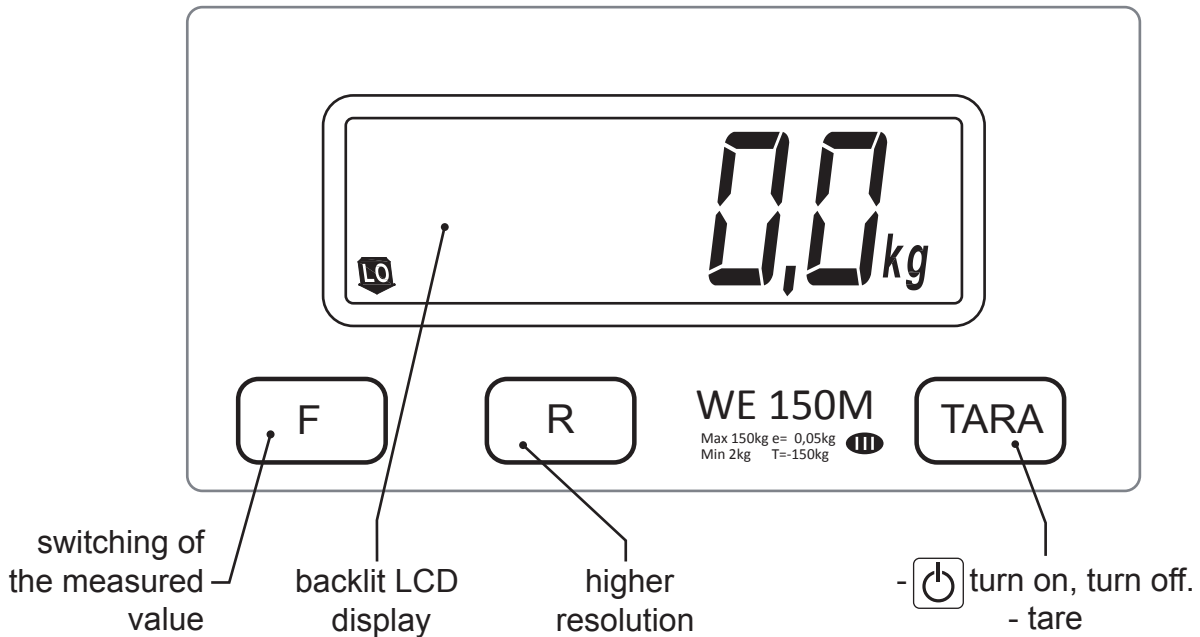

Certificate of approval type WE No. PL 06 003 issued by the Central Office of Measures (the number of a notified body: 1440).  
Certificate of Conformity No MD-220/1/2009 issued by the Polish Research and Certification Centre (Notified Body number: 1434).

#### Application

Medical scales equipped with mechanical height meter WE150P3 M are designed for weighing patients and measuring their height. Measurements are made in a standing position.



**Fig.1 View of the front panel**

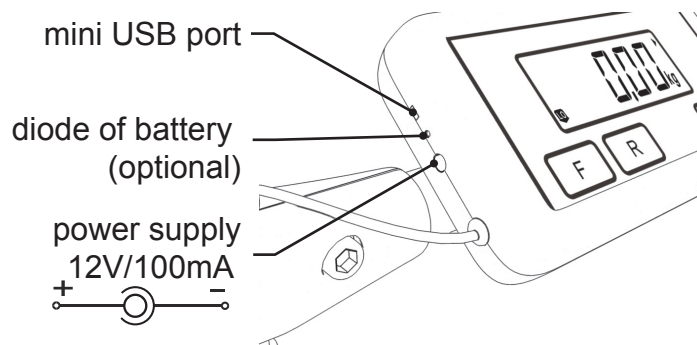

**Fig. 2 View of the left side front panel**

## Preparation of scale to work

1. Set the scale on a hard, level surface; put the scale horizontally using a spirit level and feet regulators;

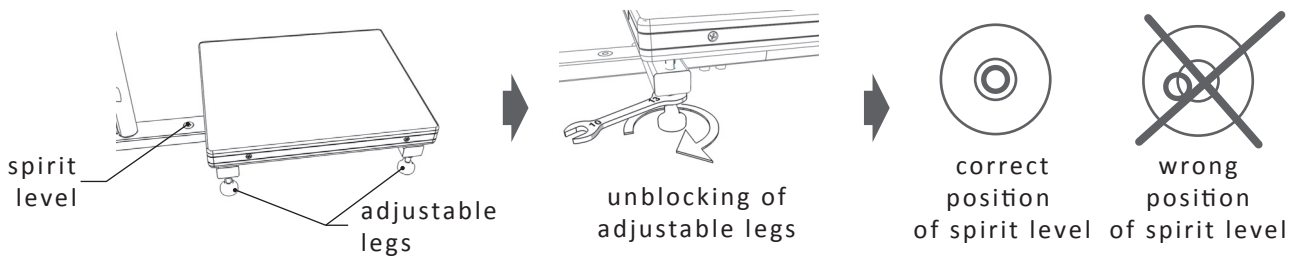

2. Turn on the power supply to the wall socket 230V, and plug of the cable into the housing of the scale

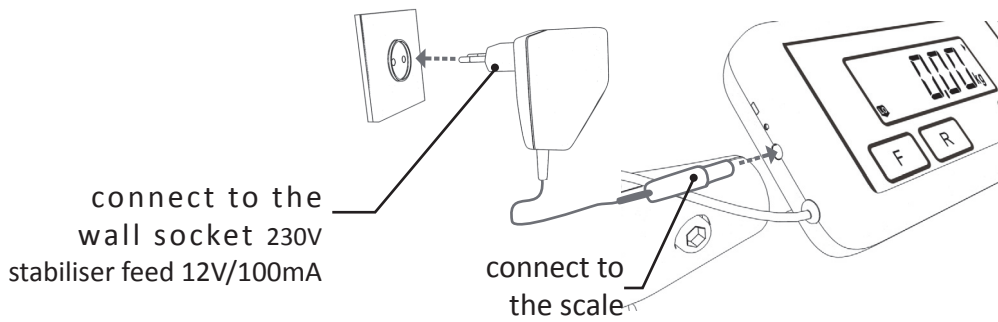

3. Push movable strip of high meter in the lowest position

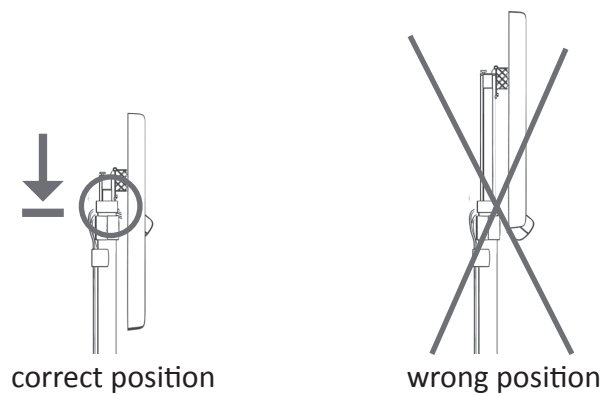

4. Press the button TARE and wait for the appearance of a big zero on the display of the scale ( the platform scale should be unloaded at this time). Index plus is flashing

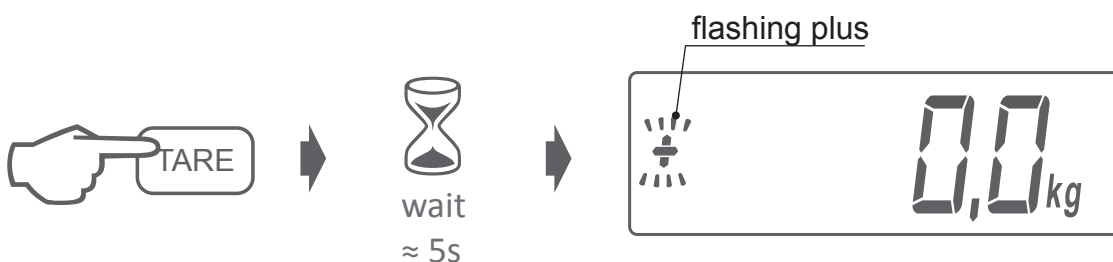

## Measuring process

Appearance on the display "small zeros" means you should wait until the "big zero" (normal) appears, if it doesn't please press the button "TARE".

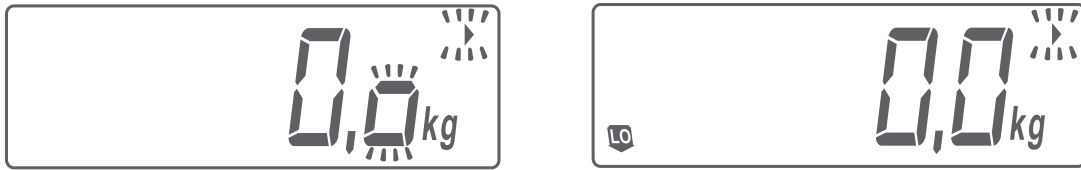

Tare device works in the whole range of scale, it reduces the weighing ranges of the scale. Over loaded weight of greater mass than Max (given on the scale) is indicated by the following information:



In the case of a zero absence on the display, it is necessary to turn off the scale and again turn it on.

5. Go on the platform scale and wait a few seconds until indication is stable

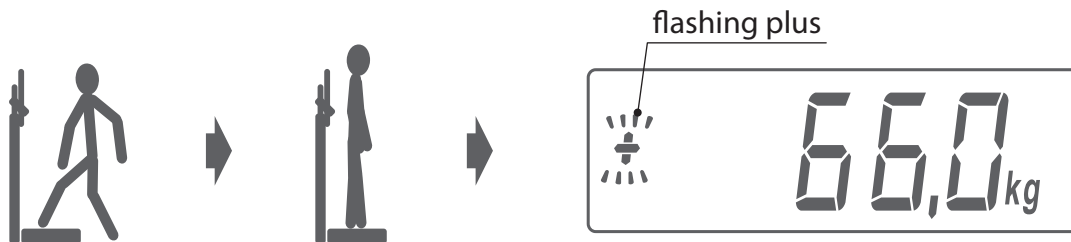

2

6. Press the button F for remembering of measuring value of mass

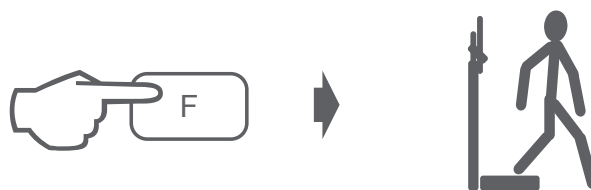

7. If you want to delete a result of mass measurement press twice the button F

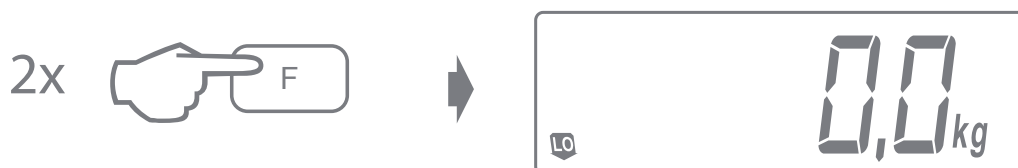

8. Put the beam of high meter on the head of the patient

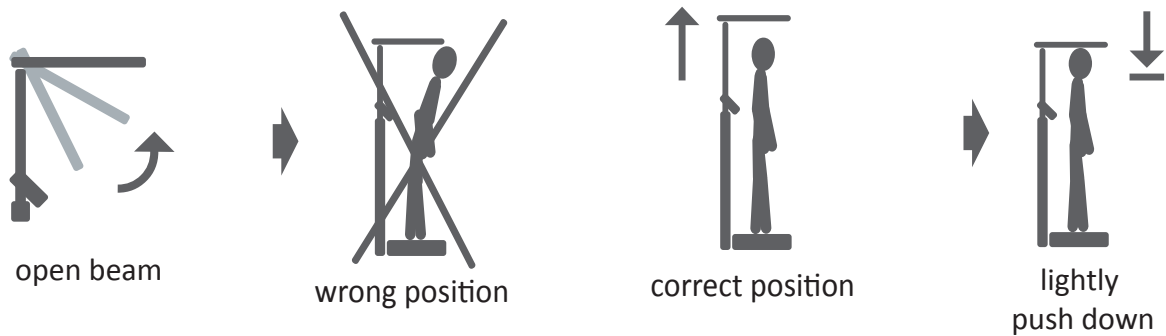

9. Measuring of height

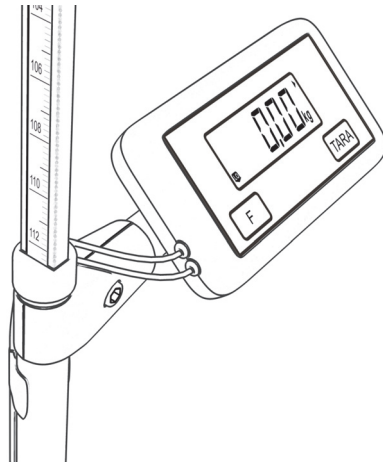

10. Turn off the scale

Press the button TARE and hold for a few seconds

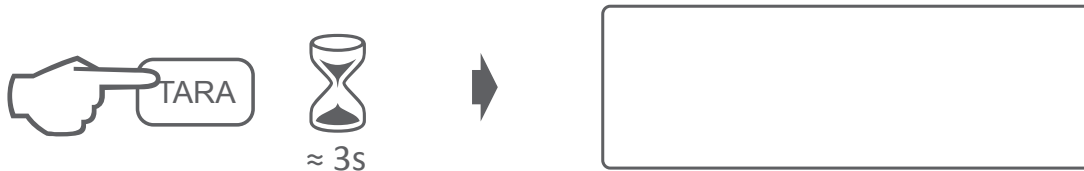

### Additional filtration

In the case of ground vibration, on which stands the scale or unstable standing people can be turn on additional filtration, indicated on the display the letters "F on."

1. In the initial state, point 4 (zero on display), press twice the button F

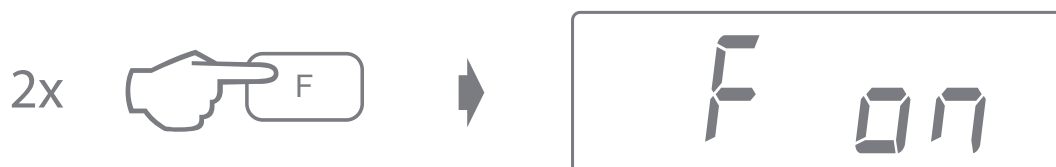

2. Pressing the button F must accept the "F on" or condition "F off", that is disabling additional filtration

3. Switching between states: "F on" and "F off" is done by pressing the TARE

## Higher resolution

If you need to accurately weigh the small increase in mass, eg determine the mass of food consumed by a child press the R button and weigh your child before feeding and after feeding.



Example of measure growth of small mass

Using higher resolution you can weigh small mass.

## Addition to the instruction of medical scales

1. The manufacturer is not liable for the consequences of using the scale, in circumstances not provided for operation, including the power supply parameters other than those listed below:
  - a. 60mA 12V DC min
  - b. Polarity
  - c. Female plug 2.1 mmx9mm
2. When you turn on the scale and the weight, moving parts (pan of the scale and its structural components) can not touch any part of the fixed - not related to the pan (wall coverings, other equipment or apparatus, etc.) This may prevent the inclusion of the scale or the wrong indication.
3. When you weighing on the baby scale, the child should be placed to prevent it from slipping from the pan. A child can not remain on the pan without adult responsible for his safety.
4. When you weighing on the personal medical scale the patient should be in a safe and stable stand with both feet on the pan.
5. In the scale of the weighting chair scale two feet of the patient should be based on the turnover brackets.
6. The manufacturer shall not be liable for the consequences of non-checking and verification in requiring period of time for particular scales referred to the convenient regulations:
  - a. Verification by the Main Measuring Office should be held before the expiry of three years from 1 December of the year in which the initial assessment of compliance. Last two digits of the year in which the initial assessment of compliance are placed on a sticker on hologram (along with the number of units certified - the office issuing the check measure weight) glued next to the plate of the scale.

*Legal basis Art 8k paragraph. 3 of the Act of 11 May 2001 Law on Measures (Dz. U of 2004 No. 243, poz.2441, 2005, No. 163, item. 1632, No. 180, 1494, from 2006 r.Nr 170 , pos. 1217, No. 249, item. 1834, 2007, No. 176, item. 1238, in 2008, No. 227, poz.1505, of 2009, No. 18, item. 97).*
  - b. The next test (re-legalization) should be carried out within 25 months from the first day of the last re-verification. Next to the plate are glued (the re-verification) 2 with the hologram sticker: monthly (Roman) and annual (two Arabic numerals).

*Legal basis: § 27 and 28 and Annex 6 of the Minister of Economy dated 7 January 2008. on legal metrological control of measuring instruments (Journal of Laws of 2008, No. 5, item 29)..*
7. Declaration and information on electromagnetic emissions (EMC). Scales are designed to work in any premises, including dwellings. Scales do not have any radio transmitters, the minimum electromagnetic emissions in the range of 9 kHz to 3 GHz is a result of the scale measurement system and practically eliminates any effect on the devices in the immediate vicinity. In accordance with BS EN 60601-1-2.
8. Declaration and information according to the resistance of the scale on factors - noise. All of the following distortions do not increase the scale of the errors above the limit values for the particular type. However there is not desirable, long-term work under boundary confounders.
  - a. Changes in the supply voltage:

The lower limit  $V_{min} = V - 15\%$ ;  
The upper limit  $V_{max} = V + 10\%$ ;
  - b. Short-term decreases in voltage electricity  
Decrease in amplitude = 100% for a half period;  
Decrease in amplitude = 50% for 2 half periods;
  - c. Electrical glitches in electricity with a value of 1 kV.
  - d. Electrostatic Discharge at least 10x at intervals of 10s:

Direct 6kV;  
Indirect (by air), 8kV;
  - e. Electromagnetic radiation: Frequency range 26 MHz to 1 GHz;  
Magnetic field of 3V / m;  
Modulation 80% AM, 1 kHz sine wave.  
*In accordance with BS EN 45501*

The use of weights in excess of the conditions in accordance with PN EN 45501 may cause damage to the weight or the wrong indication.

The manufacturer recommends to turn off mobile or other transmitters of electromagnetic waves of radio frequencies that are in close proximity (tens of centimeters) from the elements of the scale.

1. Elements of scales should be cleaned using publicly available cleaning agents used in the health sector, with the exception of measures that may stain the white and light grey structure elements of scales (e.g. iodine-containing compounds). In the absence of certainty, a try on the invisible surface scale.
2. In case of doubt as to the accuracy of scale measurements should stop and report the problem to the manufacturer or distributor.
3. The manufacturer is not liable for actions not agreed with him, such as processing, repairs, inspections.

## **The work with inside battery (Optional)**

In the scales there was used a unit of two lithium-ion battery with a charging circuit equipped with light emitting diode which is next to the power supply seat. This diode is signalling a level of charging There are possible the following conditions:

- LED isn't light - supply is not connected or with connecting supply, battery is fully charged
- LED lights continuously - supply connected, the battery during charging
- LED is blinking (frequency of blinking - tens of seconds) - supply connected, charging is interrupted, you must turn off the supply of the scale and once more turn on the supply without turning on the scale using button TARE

During charging the power supply should be connected to the scale, and the scale should be turn off (turning on the scale may cause an error loading and the need to restart the charging cycle).

- the maximum time (from full discharge to full charge) 15 hours
- the minimum working time from full charge 30 hours
- the battery life is indicated by a sign of LOW BAT in the upper left corner of the display (it appears about 10 hours before the final discharge of the battery allowing further weighing).
- to charge the battery use stabilized power supply 12V/100mA 12V/250mA
- in electronic scales equipped with a rechargeable battery for increase battery life should be use as often as it is possible

During a long time brake of the work, battery shouldn't be fully charged or completely discharged

## **The work with inside battery (Optional)**

In the scales there was used a unit of two lithium-ion battery with a charging circuit equipped with light emitting diode which is next to the power supply seat. This diode is signalling a level of charging There are possible the following conditions:

- LED isn't light - supply is not connected or with connecting supply, battery is fully charged
- LED lights continuously - supply connected, the battery during charging
- LED is blinking (frequency of blinking - tens of seconds) - supply connected, charging is interrupted, you must turn off the supply of the scale and once more turn on the supply without turning on the scale using button TARE

During charging the power supply should be connected to the scale, and the scale should be turn off (turning on the scale may cause an error loading and the need to restart the charging cycle).

- the maximum time (from full discharge to full charge) 15 hours
- the minimum working time from full charge 30 hours
- the battery life is indicated by a sign of LOW BAT in the upper left corner of the display (it appears about 10 hours before the final discharge of the battery allowing further weighing).
- to charge the battery use stabilized power supply 12V/100mA 12V/250mA
- in electronic scales equipped with a rechargeable battery for increase battery life should be use as often as it is possible

During a long time brake of the work, battery shouldn't be fully charged or completely discharged

# Declaration of Conformity

Directive 93/42/EEC, medical equipment and automatic weighing instruments Directive 90/384/EEC

## MENSOR

Department of Precision Mechanics  
A.J. Lewandowscy  
ul. Węglarska 50, 04-689 Warszawa  
[www.mensor.pl](http://www.mensor.pl)



**I conclude that medical scales of our production, the following below mentioned types meet European standards in the ISO / IEC 45501, and Council of Europe: 93/42/EEC for the first class of medical devices with measuring function and Directive 90/384/EEC for automatic weighing instruments.**

### Type of scale:

<i>description</i>	<i>designation PL</i>	<i>designation DE</i>	<i>serial number</i>	<i>amount</i>
scales for baby weighing	WE15P2	PCE-PS-15 MBS		
scales for baby weighing	WE20P2	PCE-PS-20 MBS		
personal medical scale for man	WE150P1	PCE-PS-150 MPC		
personal medical scale for man	WE200P1	PCE-PS-200 MPC		
medical chair scale	WE150P3 K	PCE-PS-150 MCS		
personal scale with mechanical measuring syst.	WE150P3 M	PCE-PS-150 MM		
personal scale with mechanical measuring syst	WE200P3 M	PCE-PS-200 MM		
personal scale with electronic measuring system	WE150P3 W	PCE-PS-150 MA		
personal scale with electronic measuring system	WE200P3 W	PCE-PS-200 MA		
personal scale with the display on the pipe arm	WE150P3	PCE-PS-150 MPS		
personal scale with the display on the pipe arm	WE200P3	PCE-PS-200 MPS		
medical bad scale	WE300P1 L	PCE-PS-300MBW		
bariatric scale	WE200P4	PCE-PS-200 MSH		
special scale for weighing patients in wheelchair	WM150P1 50x90Z	PCE-PS-150 MXL		

We hereby declare that the above medical scales meet the requirements of Annex V and Annex I of Council of the European Economic Community No. 93/42/EEC of 24 June 1993, implemented into Polish law of Medical Devices Act of 20 April 2004 and the Decree of the Minister of Health of 3 November 2004 on the basic requirements for medical devices for various purposes and the following harmonized standards: PN EN 45501, EN 61010-1, European Council Directive 73/23/EEC (Low Voltage Directive), PN 1041-2009, PN EN ISO 14971 - 2009, ISO 13485, BS 60950-2000, PN EN 60065:2001, EN 55022:2000, PN EN 55013 + A: 1997

Conformity assessment according to Annex V of Directive 93/42/EEC was performed with the involvement of a Notified Body No. 1434, and in / g directive 90/384/EEC Notified Body No. 1440th

Obtained Certificate of EC Type Approval No. PL 06 003 dated 21-04-2006 the Central Office of Measures.  
Obtained Certificate of Conformity No. MD - 220/1/2009 date of application of the CE mark – 2009.

Warsaw 2009









  
Manager  
dr inż. Janusz Lewandowski



**Digital personal scale with mechanical height meter WE150P3 M**

**Functions and features of the scale:**



-  Additional stabilization result
-  Remembering last result
-  Mini USB port
-  Backlit display
-  Weighing people
-  Measuring Growth
-  5 years warranty on measuring transmitter of mass
-  2 years warranty
-  Possible legalization

**Overview:**

Digital personal scale with mechanical height meter WE 150P3 M is equipped with backlight liquid crystal display, adjustable legs. Scale features: tare, remember the last result of weighing, and an additional filter - this feature enables stable reading during of weighing moving objects or ground vibrations, calibration for the user. Pan of the scale is covered by the black rubber, which protects the patient's legs from slipping.

**Technical specification:**





Max capacity	150kg
Min capacity	2kg
Tare range	-150kg
Display resolution	5g / 50g
Time stability indications	1-2s
Mass	7kg
Working temperature	+10°C - +40°C
Dimension of pan	25x30cm
Overall dimensions	25x44x117cm

Power supply	stabilized adapter 12V/100mA
--------------	---------------------------------

Resolution of height-meter	2mm
----------------------------	-----

Range measuring system of high	100 - 200cm
--------------------------------	-------------

**Documents:**

-  metrological certificate type WE
-  medical EC type-approval certificate
-  declaration of conformity CE compliant
-  registration of medical devices
- WHQL Certified VCP driver for USB v.2.08.02

**Additional options:**

- Li-ion battery - up to 50h on battery power to continuously work
- Connect to a computer by USB (length of 1,8m)
- Genie program allowing visualizations and registrations indicated by the scale of USB port (we execute additional modifications to the programme) - standard version for free

**Figure - Overall dimensions and weight pan [cm]:**

